

THIS DRAWING IS UNPUBLISHED. RELEASED FOR PUBLICATION  
 © COPYRIGHT BY TYCO ELECTRONICS CORPORATION. ALL RIGHTS RESERVED.

LOC	DIST	REVISIONS					
FT	0	P	LTR	DESCRIPTION	DATE	DWN	APVD
			V2	REVISED PER ECO-08-016190	07JUL08	HMR	GS

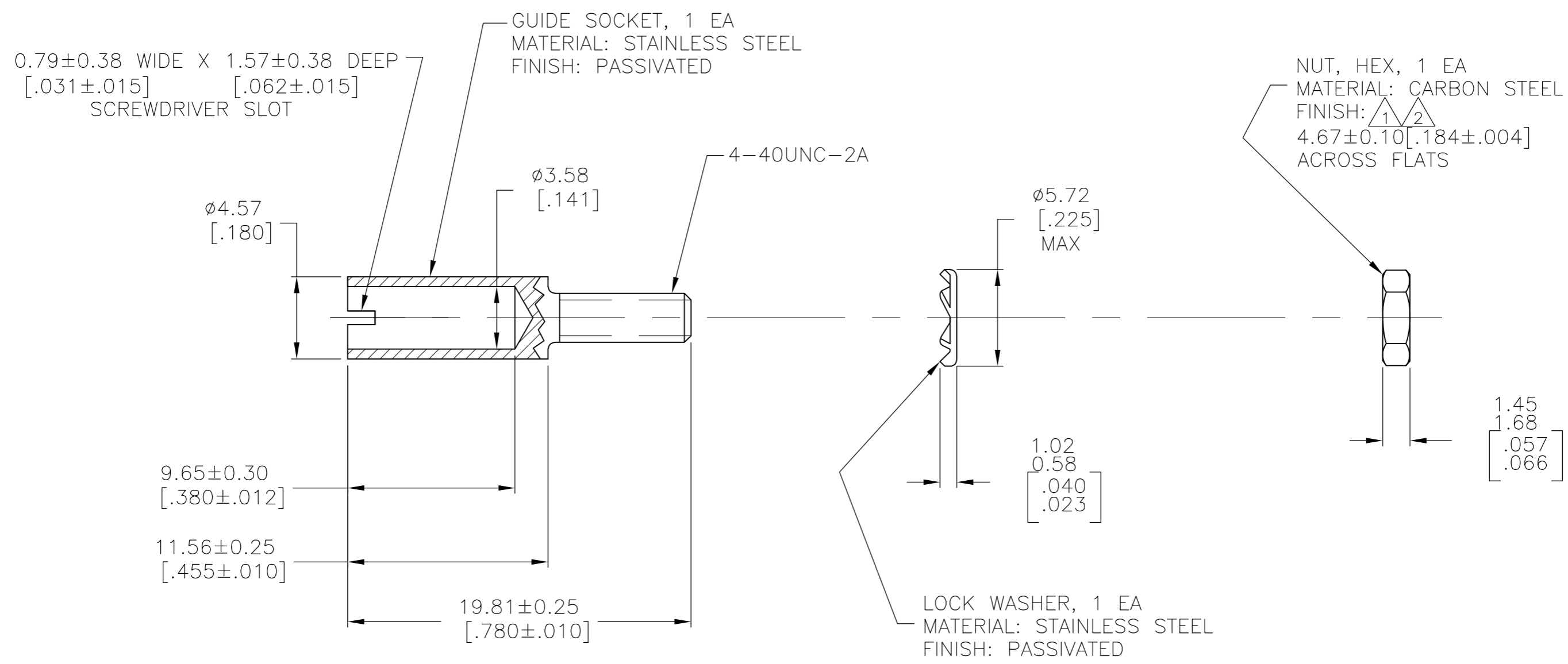

- NOTES:
- <sup>1</sup> ZINC PLATE WITH HEXAVALENT CHROMIUM.
  - <sup>2</sup> ZINC PLATE WITH NON-HEXAVALENT CHROMIUM.
  - <sup>3</sup> SPECIAL PACKAGING - ONE UNASSEMBLED UNIT PER BAG
  - <sup>4</sup> PRELIMINARY - NOT FOR PRODUCTION.

<sup>3</sup>	<sup>2</sup>	<sup>4</sup>	1-200390-0
	<sup>2</sup>		200390-9
<sup>1</sup>			200390-2
NUT FINISH		PART NUMBER	

THIS DRAWING IS A CONTROLLED DOCUMENT.		DWN W.G.LENKER 1-20-95	Tyco Electronics Corporation Harrisburg, Pa 17105-3608	
DIMENSIONS: mm [INCHES]		CHK R.STONE 1-24-95		
TOLERANCES UNLESS OTHERWISE SPECIFIED:		APVD -	NAME	
0 PLC ± - 1 PLC ± - 2 PLC ± 0.13 [.005] 3 PLC ± - 4 PLC ± - ANGLES ± -		PRODUCT SPEC -	CENTER GUIDE SOCKET KIT, UNASSEMBLED, M SERIES	
MATERIAL SEE CALLOUT		FINISH SEE CALLOUT	APPLICATION SPEC -	RESTRICTED TO -
		WEIGHT -	SIZE A3	CAGE CODE 00779
		CUSTOMER DRAWING	DRAWING NO C-200390	REV V2
		SCALE 4:1	SHEET 1 OF 1	